

# JA SERIES

## OWNER'S MANUAL



# POWER AMPLIFIER

## JA1CH JA2CH JA4CH JA5CH

### INSTALLATION / OWNER'S MANUAL

The Bluetooth® word mark and logos are owned by the Bluetooth® SIG, Inc. Other trademarks and trade names are those of their respective owners.



### Customer Support

1-888-921-4088

(Monday-Friday, 9AM-5PM EST)

Visit <https://www.jensenmobile.com>

Designed and Engineered in USA



# JENSEN®

Namsung America Inc.  
©2025 Namsung America Inc.  
All rights reserved.

All rights reserved. No part of this publication may be reproduced, distributed, or transmitted in any form or by any means, including photocopying, recording, or other electronic or mechanical methods, without the prior written permission of NAMSUNG AMERICA INC.

NSC0625-V02

# JENSEN®

## Preparation

Please read entire manual before installation. Due to the technical nature of amplifiers, it is highly recommended that your amplifier is installed by a professional installer or an authorized dealer.

### Before You Start

- Disconnect negative battery terminal. (consult a qualified technician for instructions)
- Avoid installing the amplifier where it would be subject to high temperatures, such as from direct sunlight, or where it would be subject to dust, dirt or excessive vibration.
- Use extreme caution when drilling holes to avoid damaging fuel lines or existing vehicle wiring.
- All amplifier installations require power, signal and speaker wires (not included).
- An amplifier installation kit (sold separately) is highly recommended to facilitate the installation. Consult your dealer for recommendations.

### Mounting Location

- Choose a mounting location for the amplifier. Suggested locations include under a seat or in the trunk.
- The amplifier can be mounted horizontal (recommended) or vertical. For optimum performance, make sure to provide at least 1" of space around all sides. Do not mount the amplifier under carpets or where airflow is restricted.
- Do not install the amplifier where it may be exposed to moisture.
- The optimum mounting location varies between vehicles. Remember to test all amplifier functions before completing the final mounting procedure.

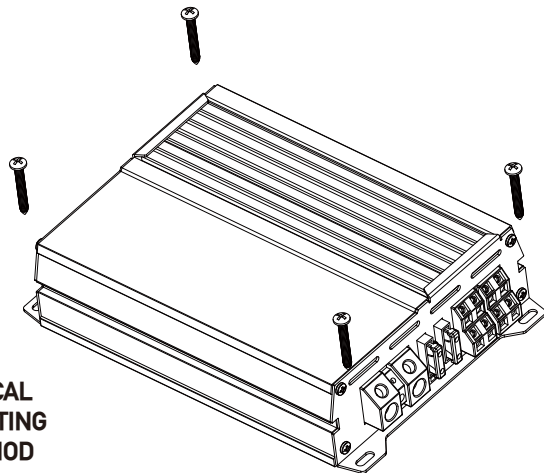

**TYPICAL  
MOUNTING  
METHOD**

## Limited Two Year\* Warranty

This warranty gives you specific legal rights. You may also have other rights which vary from state to state.

Jensen warrants this product to the original purchaser to be free from defects in material and workmanship for a period of two years from the date of the original purchase.

Jensen agrees, at our option, during the warranty period, to repair any defect in material or workmanship or to furnish an equal new, renewed, or comparable product (whichever is deemed necessary) in exchange without charges, subject to verification of the defect or malfunction and proof of the date of purchase. Subsequent replacement products are warranted for the balance of the original warranty period.

**What is covered?** This warranty covers all defects in the material and workmanship in this product. The following are not covered: software, installation/removal costs, damage resulting from accident, misuse, abuse, neglect, product modification, improper installation, incorrect line voltage, unauthorized repair, or failure to follow instructions supplied with the product, or damage occurring during return shipment of the product. Specific license conditions and copyright notices for the software can be found via [www.jensenmobile.com](http://www.jensenmobile.com).

### Warranty Coverage

\* Limited 2-year warranty. (Proof of purchase required)

- Extended Coverage: Extend your warranty from 2 years to 4 years when you register online at [www.jensenmobile.com](http://www.jensenmobile.com). Registration must be completed within 60 days of the original purchase date to qualify for this extension.

### What to do?

1. Before you call for service, check the troubleshooting guide in your owner's manual. A slight adjustment of any custom controls may save you a service call.
2. If you require service during the warranty period, you must carefully pack the product (preferably in the original package) and ship it by prepaid transportation with a copy of the original receipt from the retailer to an authorized service center.
3. Please describe your problem in writing and include your name, a return UPS shipping address (P.O. Box not acceptable), and a daytime phone number with your shipment.
4. For more information and for the location of the nearest authorized service center please contact us by one of the following methods:
  - a. Call us toll-free at (888) 921-4088 (Monday-Friday, 9:00 am, to 5:00 pm, EST)
  - b. E-mail us at [cs@jensenmobile.com](mailto:cs@jensenmobile.com)

**Exclusion of Certain Damages:** This warranty is exclusive and in lieu of any and all other warranties, expressed or implied, including without limitation the implied warranties of merchantability and fitness for a particular purpose and any obligation, liability, right, claim or remedy in contract or tort, whether or not arising from the company's negligence, actual or imputed. No person or representative is authorized to assume for the company any other liability in connection with the sale of this product. In no event shall the company be liable for indirect, incidental, or consequential damages.

## Troubleshooting

Problem	Cause	Action
Unit will not turn on (no power LED indicator)	+12V wire not connected or incorrect voltage. REM wire not connected or incorrect voltage	Check connections for proper voltage (11~16VDC)
	GND wire not connected	Check connection to ground
	Fuse(s) blown	Replace fuse(s)
Unit has power - LED is green (but no sound)	Speaker wires not connected	Check connections at speakers
	Volume turned all the way down	Increase volume level at head unit
	One or more speaker wires touching each other or touching chassis ground	Insulate all bare speaker wires from each other and chassis ground
	Speaker(s) defective or damaged	Check/replace speaker(s)
	Input signal not connected	Check high or low level inputs for proper connection
Unit blows fuse(s)	Incorrect fuse rating	Use fuse(s) with correct rating
	+12V wire touching chassis ground	Check for pinched wire
	Speaker(s) defective or damaged	Check/replace speaker(s)
Engine noise	Bad ground connection	Make sure amplifier is grounded to clean bare metal
	Signal ground loop or RFI (radio frequency interference)	Re-route RCA cables from existing high current wiring
LED illuminates red (protect mode)	One or more speaker wires touching each other or touching chassis ground	Insulate all bare speaker wires from each other and chassis ground
	Speaker(s) defective or damaged internally (shorted)	Check/replace speaker(s)
	Speaker load less than 2 ohms (stereo). Speaker load less than 4 ohms (bridged)	Adjust speaker load - amplifier will not operate at less than 4 ohms when bridged
Distorted audio output	Incorrect input signal type or input level too high	Check connections and reduce/adjust input level
Low audio output	Incorrect input signal type or input level too low	Check connections and increase/adjust input level

## Connection Descriptions

### NOTE:

Be sure to follow specific instructions included with your amplifier installation kit (not included with this amplifier). The information below should be used as a general guideline only.

### Power Wire (+12V)

- Disconnect negative battery terminal before proceeding. Consult a qualified technician for instructions if you are unsure.
- Plan wire routing before cutting any wires to length. Begin by routing the power +12V wire from the battery to the amplifier location. Use a grommet when running wires through the firewall or metal openings. Avoid running the power wire near existing vehicle wiring to prevent induced noise from entering the audio system.
- Use extreme caution when drilling holes to avoid damaging fuel lines or existing vehicle wiring.
- The +12V wire MUST be fused within 18" of the battery for protection of the vehicle's electrical system.

### Ground Wire (GND)

- The amplifier ground wire should be as short as possible (no more than 36" or 1 meter). Choose a clean unpainted section of metal or the vehicle chassis when attaching the ground connection. Be sure to clean the area of any dirt or grease.

### Remote Turn-on Wire (REM)

- The remote turn-on wire connects to the head unit's amplifier turn-on lead or power antenna output.

### Speaker Wires

- Choose adequate gauge speaker wire depending on your exact amplifier/speaker combination. Be sure to observe polarity when connecting.
- Do not ground any speaker wires or connect any speaker wires together.

### Input Signal

- The amplifier's input signal connects to the head unit's low level (RCA) or high level (speaker wire) outputs.
- Low level input signals deliver the best performance. If unavailable, use the high level inputs - when interfacing with factory head unit for instance.

### Power / Protect Indicators

- Colored LED indicators illuminate from the plastic power terminal.
- The blue LED illuminates during normal operation (**POWER**) and the red LED indicator is visible when the amplifier detects a fault (**PROTECT**).

### CAUTION

- Do not use both low and high level inputs at the same time. Connect only one or the other.
- Keep low level inputs away from any power wires to avoid engine noise.
- Never run any wires underneath or outside the vehicle.

# Audio Inputs and Controls

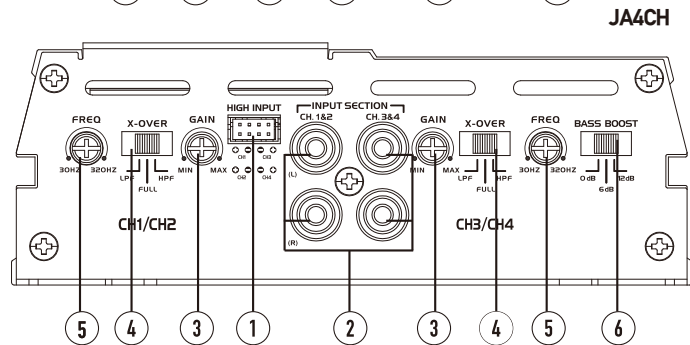
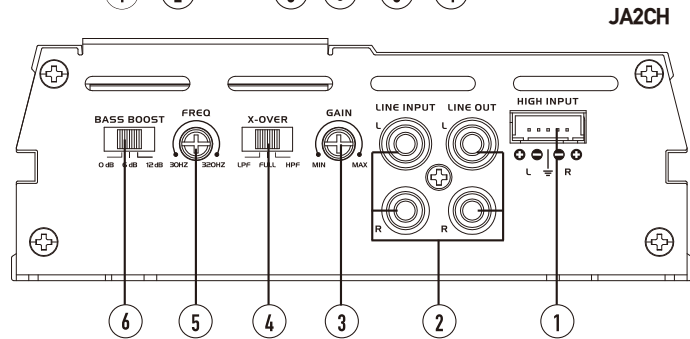
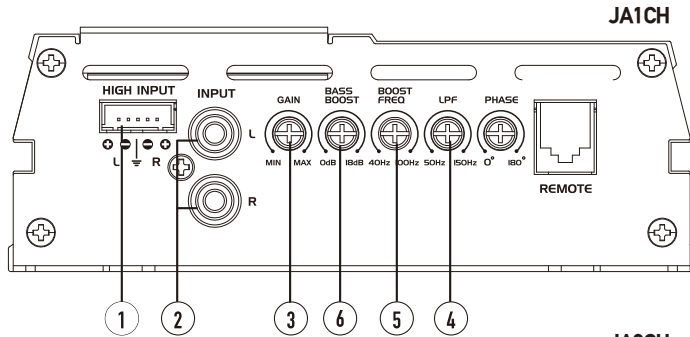

- |                                    |                     |
|------------------------------------|---------------------|
| 1 High-Level Inputs (Speaker Wire) | 4 Crossover Control |
| 2 Line In / Line Out (RCA)         | 5 Frequency         |
| 3 Gain                             | 6 Bass Boost        |

# Specifications



## JA5CH

- Class D design
- Low level inputs (RCA)
- Variable gain adjustment (200 mV ~ 6 V)
- Selectable crossover (high pass/low pass/full range)
- Variable low-pass crossover (50 Hz ~ 150 Hz)
- Variable high-pass crossover (40 Hz ~ 250 Hz)
- Wired bass remote
- PWM MOSFET power supply
- 2 Ohm stable operation
- Recommended power/ground wire: 8 AWG
- Recommended speaker wire: 12 AWG
- Fuse: 40 A x 2
- Amplifier dimensions: 2.00" x 5.63" x 11.00" (HxDxW)

## Power Output:

- Continuous Power Output (1% THD+N):
- 70 Watts RMS x 4 channels + 240 Watts RMS x 1 channel @ 4 ohms
- 100 Watts RMS x 4 channels + 350 Watts RMS x 1 channel @ 2 ohms
- 200 Watts RMS x 2 channels @ 4 ohms (bridged)
- Maximum dynamic power: 1500 Watts
- THD+N: <0.15% @ 1 Watt RMS
- Frequency response: 20Hz ~ 20kHz, 20Hz ~ 150Hz
- Signal to noise ratio 90 dBA (reference: 1 Watt RMS @ 4ohm)

# Specifications

## JA1CH

- Class D design
- High level inputs (speaker wire)
- Low level inputs (RCA)
- Variable gain adjustment (200 mV - 6 V)
- Built-in crossover (low pass)
- Variable low-pass crossover (50 Hz - 150 Hz)
- Variable bass boost @ 40 Hz (0-18 dB)
- 1/2/4 Ohm Speaker impedance
- Recommended power/ground wire: 8 AWG
- Recommended speaker wire: 12 AWG
- Fuse: 20A x 3
- Amplifier dimensions: 2.00" x 5.63" x 8.24" (HxDxW)



- Continuous power output (1% THD+N):
  - 240 Watts RMS x 1 channels @ 4 ohms
  - 400 Watts RMS x 1 channels @ 2 ohms
  - 600 Watts RMS x 1 channels @ 1 ohms
- Maximum dynamic power: 1000 Watts
- THD+N: <0.15% @ 1 Watt RMS
- Frequency response: 20Hz - 150kHz
- Signal to noise ratio 90 dBA (reference: 1 Watt RMS)

## JA2CH

- Class D design
- High level inputs (speaker wire)
- Low level inputs (RCA)
- Variable gain adjustment (200 mV - 6 V)
- Selectable crossover (high pass/low pass/full range)
- Variable low-pass crossover (30 Hz - 320 Hz)
- Variable high-pass crossover (30 Hz - 320 Hz)
- Selectable bass boost @ 50 Hz (0/6/12dB)
- PWM MOSFET power supply
- RCA pass-thru outputs
- Bridgeable operation for subwoofer applications
- 2 Ohm stable stereo operation



- Recommended power/ground wire: 8 AWG
- Recommended speaker wire: 16 AWG
- Fuse: 25A
- Amplifier dimensions: 2.00" x 5.63" x 6.43" (HxDxW)
- Continuous power output (1% THD+N):
  - 80 Watts RMS x 2 channels @ 4 ohms
  - 120 Watts RMS x 2 channels @ 2 ohms
  - 240 Watts RMS x 1 channels @ 4 ohms (bridged)
- Maximum dynamic power: 600 Watts
- THD+N: <0.15% @ 1 Watt RMS
- Frequency response: 20Hz - 20kHz
- Signal to noise ratio 100 dBA (reference: 1 Watt RMS @ 4ohm)

## JA4CH

- Class D design
- High level inputs (speaker wire)
- Low level inputs (RCA)
- Variable gain adjustment (200 mV - 6 V)
- Selectable crossover (high pass/low pass/full range)
- Variable low-pass crossover (30 Hz - 320 Hz)
- Variable high-pass crossover (30 Hz - 320 Hz)
- Selectable bass boost @ 50 Hz (0/6/12dB)
- PWM MOSFET power supply
- Bridgeable operation for subwoofer applications
- 2 Ohm stable stereo operation
- Stereo/bridged simultaneous operation



- Recommended power/ground wire: 8 AWG
- Recommended speaker wire: 16 AWG
- Fuse: 25 A x 2
- Amplifier dimensions: 2.00" x 5.63" x 8.24" (HxDxW)
- Continuous power output (1% THD+N):
  - 80 Watts RMS x 4 channels @ 4 ohms
  - 120 Watts RMS x 4 channels @ 2 ohms
  - 240 Watts RMS x 2 channels @ 4 ohms (bridged)
- Maximum dynamic power: 1000 Watts
- THD+N: <0.15% @ 1 Watt RMS
- Frequency response: 20Hz - 20kHz
- Signal to noise ratio 100 dBA (reference: 1 Watt RMS @ 4ohm)

# Audio Inputs and Controls

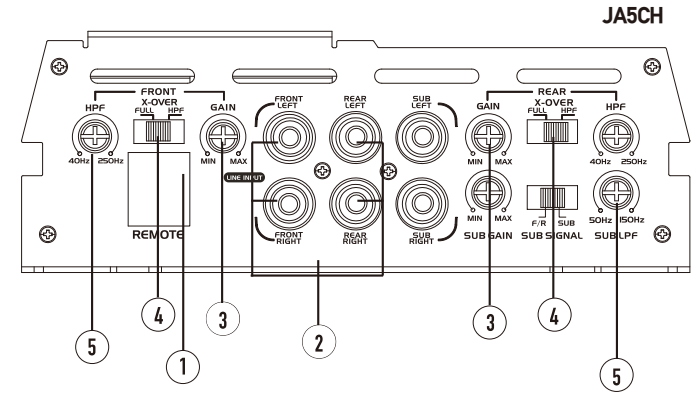

- |                            |                     |
|----------------------------|---------------------|
| ① Remote                   | ④ Crossover Control |
| ② Line In / Line Out (RCA) | ⑤ Frequency         |
| ③ Gain                     |                     |

# Power and Speaker Connections

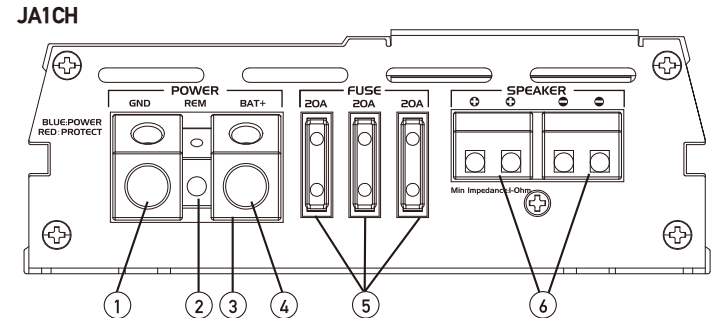

- |                     |                             |
|---------------------|-----------------------------|
| ① Ground Connection | ④ +12VDC Battery Connection |
| ② Remote Turn On    | ⑤ Fuse(s)                   |
| ③ Power/Protect LED | ⑥ Speaker Connections       |

# Power and Speaker Connections

JA2CH

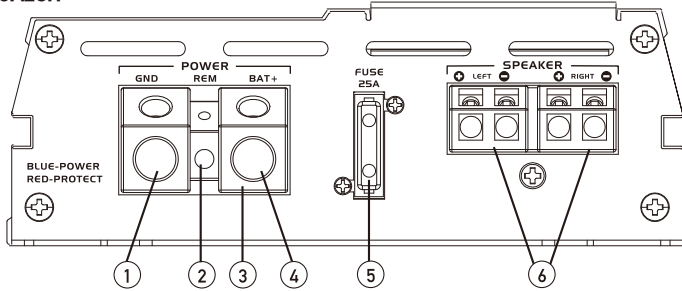

JA4CH

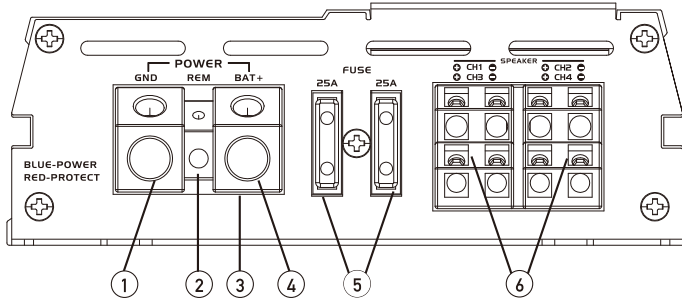

JA5CH

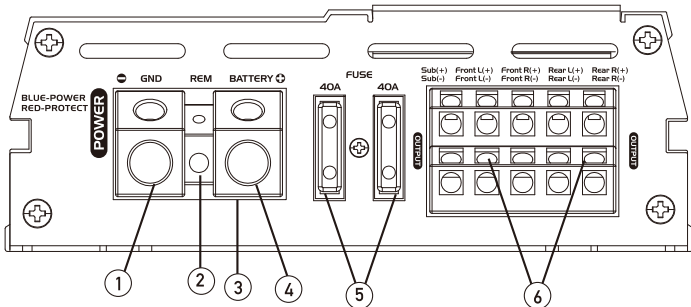

- |                     |                             |
|---------------------|-----------------------------|
| ① Ground Connection | ④ +12VDC Battery Connection |
| ② Remote Turn On    | ⑤ Fuse(s)                   |
| ③ Power/Protect LED | ⑥ Speaker Connections       |

# Configuration/Setup

## Input level Control

The input level control (gain) is used to obtain the best possible match between the head unit audio output and the amplifier input. Begin by turning the input level control fully counterclockwise. Next, turn up the head unit volume control around 3/4 of the way up. Adjust the input level control clockwise until audible distortion is heard, then slightly counterclockwise to provide the best match. Repeat for all input level controls.

## Crossover Mode

The crossover is used to filter out frequencies above or below a certain point. Choose **LPF** when using the amplifier with subwoofers, **HPF** when using with midrange/tweeter combinations and **FULL** when using with coaxial-type speakers.

**Note:** Choose **FULL** when using the amplifier in stereo/bridged simultaneous mode. In this mode, passive crossovers are required. Failure to use the correct passive components may damage the amplifier and/or speakers. Consult a qualified professional for recommendations.

## Crossover Control

This control allows precise adjustment of the crossover frequency.

## Bass Boost

This control provides additional boost @ 45Hz when used with subwoofers. Adjust this control with caution - as improper use can damage speakers!

## Power / Protect Indicators

Colored LED indicators illuminate from the plastic power terminal. The blue LED illuminates during normal operation (**POWER**) and the red LED indicator is visible when the amplifier detects a fault (**PROTECT**).

# Amplifier Connections

## Speaker Connections

Connect speaker wires observing polarity. The minimum impedance load for the amplifiers is 2 ohms stereo and 4 ohms bridged. Use of loads lower than these is not recommended and may cause amplifier damage. The amplifiers can be wired for stereo, bridged or stereo/bridged simultaneous operation.

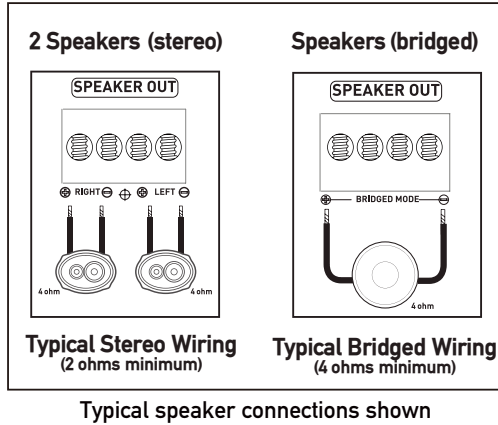

## Input Signal Connections

### Low Level Input (RCA)

Low level (RCA) input signal is preferred for best performance. Typical trunk-mount amplifier installations require a 17-20 foot RCA cable. Most trucks and under-seat applications require a 6-9 foot RCA cable. Using twisted pair construction RCA cables will minimize noise.



### High Level Input

#### (Speaker Wire)

High level inputs should only be used when RCA outputs are not available from the head unit. Connect the head unit speaker outputs to the high level input connector as shown below. The black wire (signal reference ground) may or may not require a connection to chassis ground - depending on your particular installation.

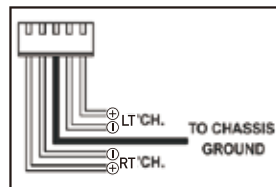

**Note:** Do not use both low and high level inputs at the same time - connect only one or the other.

# Typical Wire Routing JA1CH

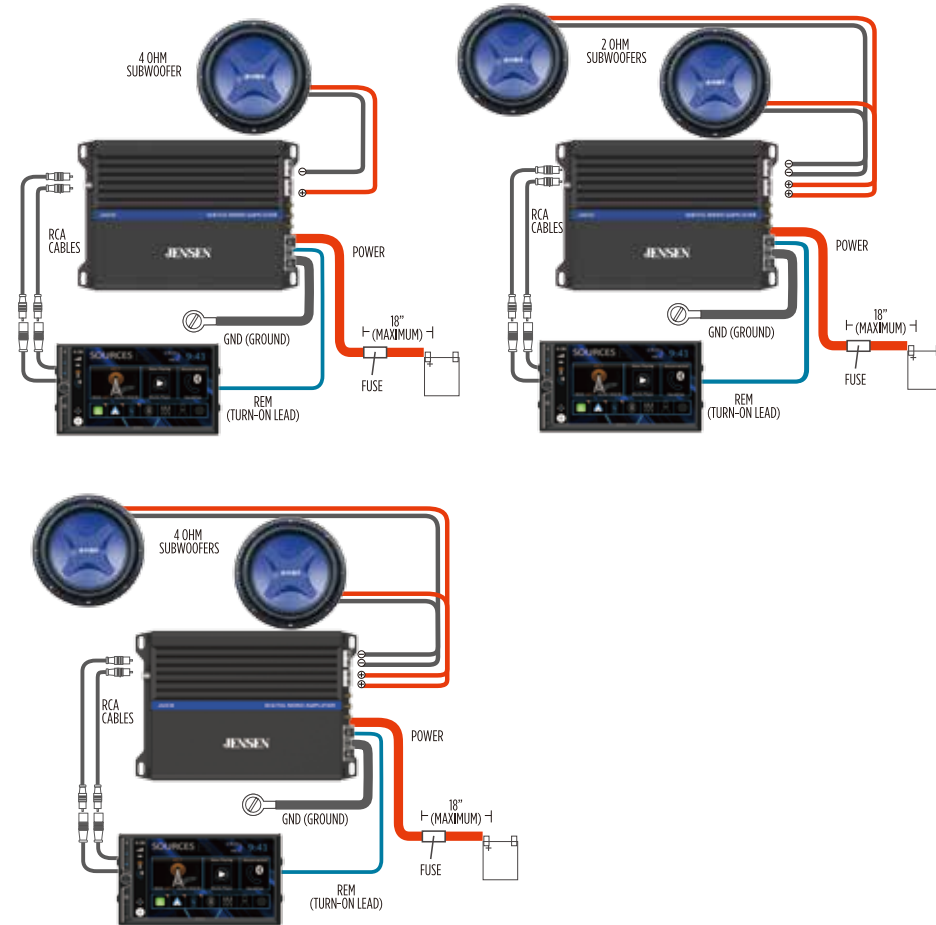

## Typical Wire Routing JA4CH

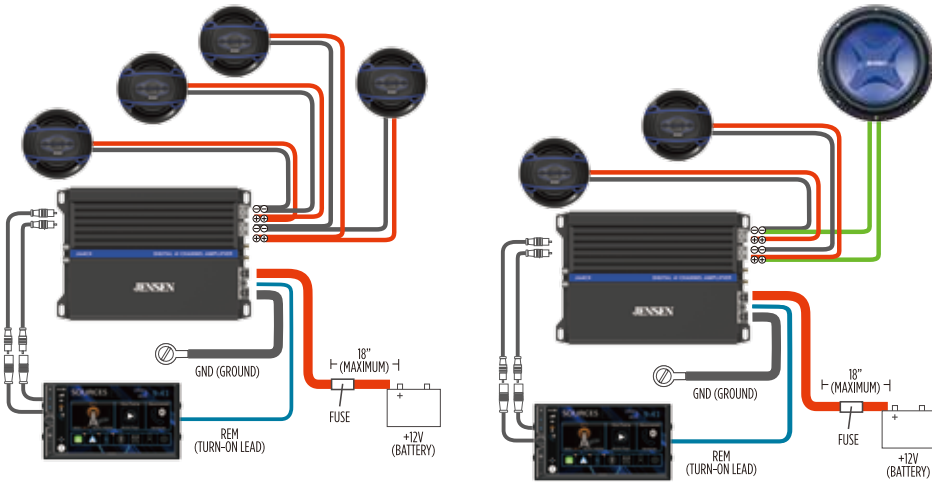

## Typical Wire Routing JA2CH

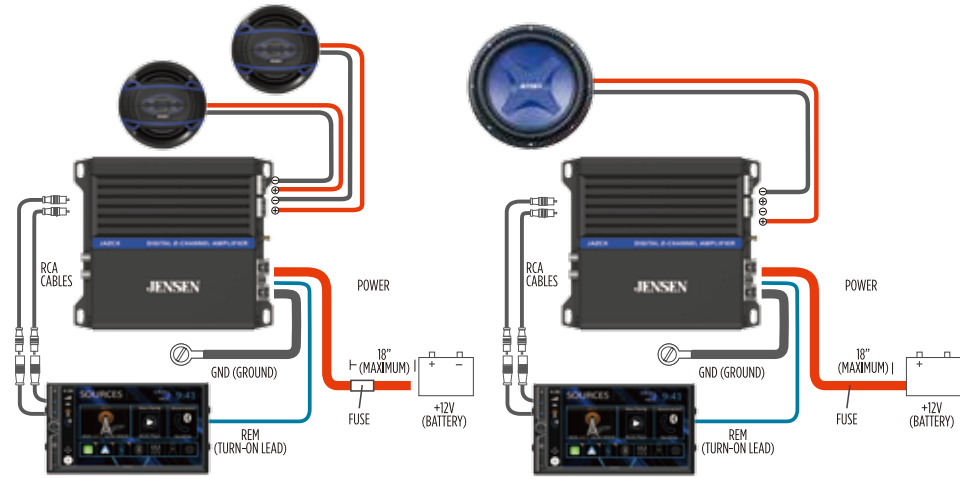

## JA5CH

